

PART NO.
661009WV053
DWG NO.
C6610WV

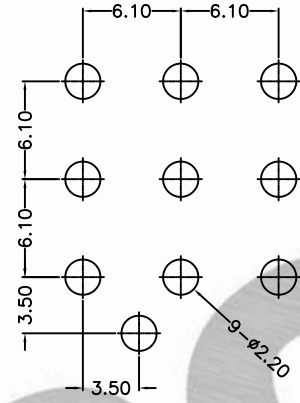

Panel Layout

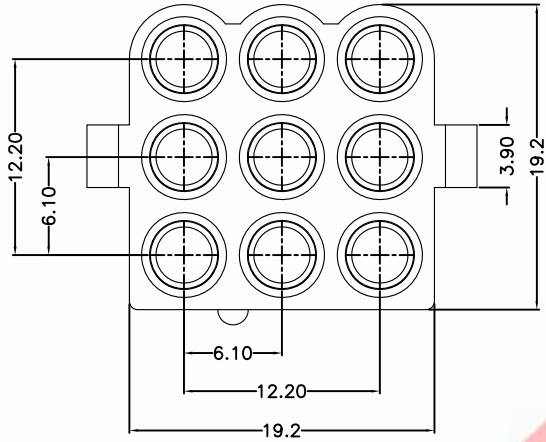
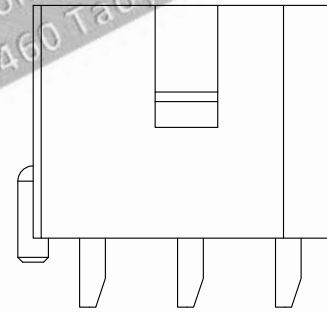
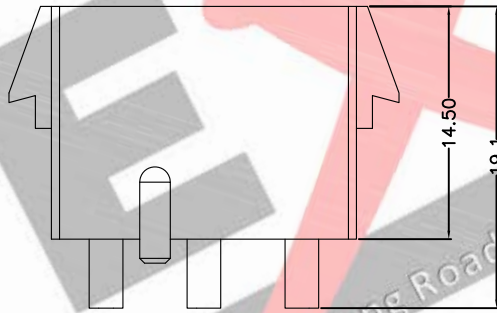
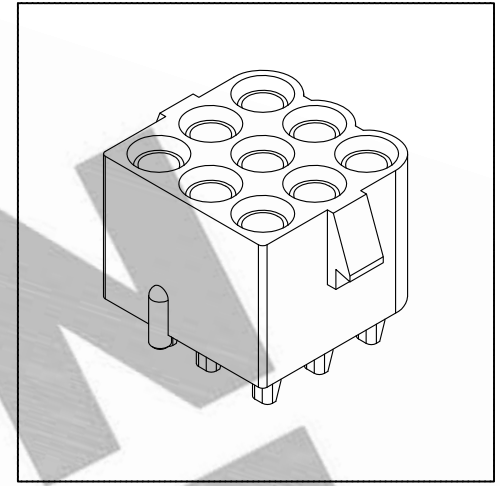

NOTE:

1. Wafer Material: Nylon PA 66 V2 black color.
2. Insulation resistance: 1000M ohm/min.
3. Withstand voltage: 1500V AC/minute.
4. Current retang: 17A AC/DC.
5. Voltage rating: 600V AC/DC

				UNLESS OTHERWISE SPECIFIED TOLERANCES		EXCON EXCON TECHNOLOGY COMPANY
				3 PLACE ±0.5 ±0.10		
				2 PLACE ±1.5 ±0.25		PART.NO
				1 PLACE ±2.0 ±0.50		
				ANGLE DIM		661009WV053
REV.	REVISIONI		DIS	DATE		
SCALE	REV.	PAGE:	UNIT	mm	DWG NO:	
2/1	A	1	THIRD ANGLE PROJECTION		C6610WV	